



EXPLORE THE CLIMATE

# **CE376 COMPACT AUTOMATIC AEROSOL LIDAR**

**User Manual (rev. July 2024)**

## TABLE OF CONTENTS

|   |           |
|---|-----------|
| <b>PACKAGE CONTENTS</b> .....                 | <b>1</b>  |
| <b>SPECIFICATIONS</b> .....                   | <b>2</b>  |
| <b>SAFETY INFORMATION</b> .....               | <b>3</b>  |
| <b>GETTING TO KNOW YOUR CE376 LIDAR</b> ..... | <b>4</b>  |
| <b>GETTING STARTED: PREREQUISITES</b> .....   | <b>4</b>  |
| <b>LIDAR INSTALLATION</b> .....               | <b>6</b>  |
| <b>THERMAL ENCLOSURE OPTIONS</b> .....        | <b>9</b>  |
| <b>HEALTH &amp; CARE</b> .....                | <b>10</b> |
| <b>WARRANTY INFORMATION</b> .....             | <b>13</b> |
| <b>CUSTOMER SUPPORT</b> .....                 | <b>13</b> |

## PACKAGE CONTENTS

- 1 x CE376 LiDAR
- 1 x Flight-case
- 1 x Power supply cable (5 m)
- 1 x Ethernet Communication cable (20 m)
- 1 x Ethernet-USB converter
- 1 x USB-B to USB-A cable
- 1 x User Manual
- 1 x USB key with software and calibration files

EXPLORE THE CLIMATE

**SPECIFICATIONS**

|                                  |  |
|----------------------------------|--|
| <b>Power Supply</b>              | 100 -250 VAC 50/60 Hz                              |
| <b>Fuse Characteristics</b>      | Slow blow T6.3A                                    |
| <b>Typical Power Consumption</b> | 40 W   |
| <b>Maximum Power Consumption</b> | 200 W  |
| <b>Operating Conditions</b>      | <u>Temperature:</u><br>+18°C – +28°C / 65°F – 82°F |
|                                  | <u>Humidity:</u><br>5% to 50%                      |
| <b>Storage Conditions</b>        | +10°C to +35°C<br>No condensation                  |
| <b>Dimensions</b>                | 713 x 463 x 691 mm /<br>28 x 18.2 x 26.8 in        |
| <b>Weight</b>                    | 35 kg / 77 lb (GPN)                                |
| <b>Computer interface</b>        | USB 2.0  |
| <b>Acquisition Mode</b>          | Photon counting                                    |
| <b>Acquisition time</b>          | < 1 s  |
| <b>Maximum range measurement</b> | 30720 m  |
| <b>Minimum range measurement</b> | 50 m   |
| <b>Range resolution</b>          | 15 m   |

**NIR CHANNELS**

|                                   |                                |
|-----------------------------------|--------------------------------|
| <b>Available in CE376 models</b>  | GPN, GN, N                     |
| <b>Wavelength</b>                 | 808 nm                         |
| <b>EYE-SAFE</b>                   | IEC 60825-1 compliant Class 1M |
| <b>Depolarization Channel</b>     | NO                             |
| <b>Emission Divergence</b>        | 450 µrad                       |
| <b>Reception FOV (full angle)</b> | 510 µrad                       |

**GREEN CHANNELS**

|                                   |                                |       |
|-----------------------------------|--------------------------------|-------|
| <b>Available in CE376 models</b>  | GPN, GP                        | GN, G |
| <b>Wavelength</b>                 | 532 nm                         |       |
| <b>EYE-SAFE</b>                   | IEC 60825-1 compliant Class 2M |       |
| <b>Depolarization Channel</b>     | YES                            | NO    |
| <b>Emission Divergence</b>        | 420 µrad                       |       |
| <b>Reception FOV (full angle)</b> | 550 µrad                       |       |

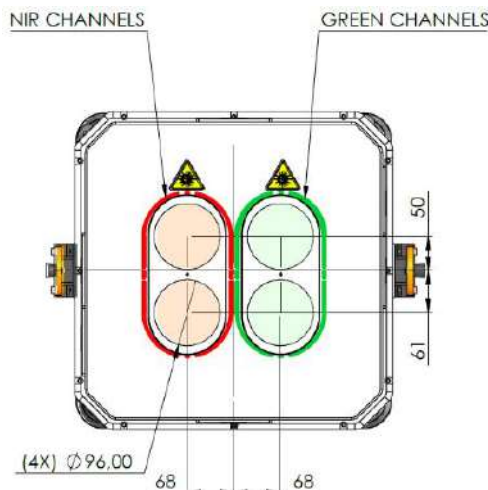

## READ AND SAVE THESE INSTRUCTIONS

### SAFETY INFORMATION

To reduce the risk of electric shock, eye-damage or other injury, please follow all instructions and safety guidelines.

#### GENERAL SAFETY

- Only use your CE376 LiDAR as described in this manual.
- Do not use your CE376 LiDAR outdoors. It is not waterproof.
- Do not use in excessively humid areas (RH > 50%).
- Do not use your CE376 in a closed room without a roof window or a hatch above it.
- It requires at least 2 persons to lift a CE376 LiDAR. Take care to use your leg muscles instead of your back. Keep the CE376 LiDAR steady when moving.
- Do not drop, hit, flip or lay your CE376 LiDAR on its sides. Any of these actions might demand the technical intervention of a CIMEL-qualified operator.
- Do not remove the cover of your CE376 LiDAR.
- Do not cover the vents.
- Do not place any heavy objects on the CE376 LiDAR.
- Do not try to put any object or hands inside your CE376 LiDAR through vents or traps.
- Do not use your CE376 LiDAR if it is damaged or not working correctly, or if the power supply cable or plug is damaged. Do not try to repair or re-align it yourself. Contact Customer Support (see p.12).

#### LASER SAFETY



- The CE376 LiDAR complies with IEC-60825-1, classified as Class 2M / Class 1M (according to the model of your LiDAR). This classification indicates that the laser is safe under reasonably foreseeable conditions of operation, but direct eye exposure to the laser beam should be avoided to prevent any potential harm.
- Do not stare inside your CE376 LiDAR through the windows when it is switched ON. The laser beam is considered safe with blink reflex (0.25 s) but can damage retina for longer exposure.
- Do not look inside your CE376 LiDAR through a magnifying glass or any optical instruments when it is switched ON.
- Do not open your CE376 LiDAR, or make it work without its cover. There is an eye safety danger. CIMEL cannot be held responsible for any injury occurring when the cover is removed.
- Restrict access to the LiDAR's operation zone to authorized personnel only

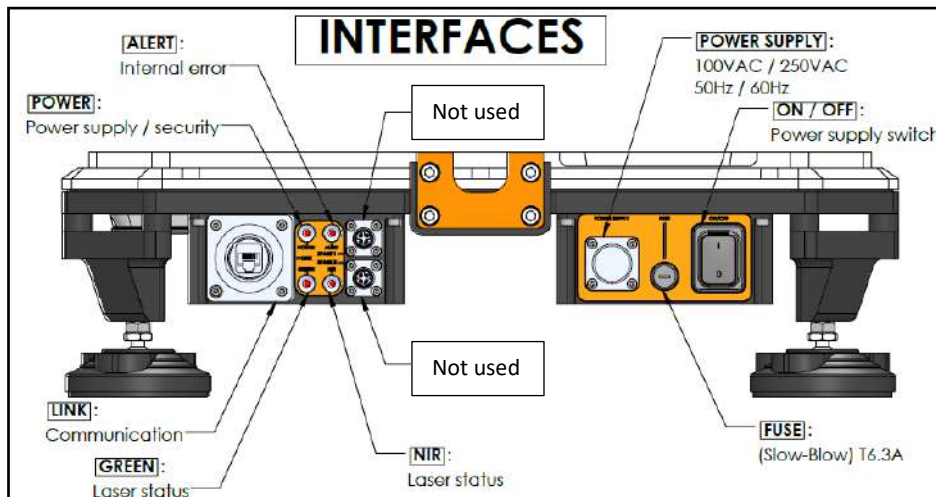
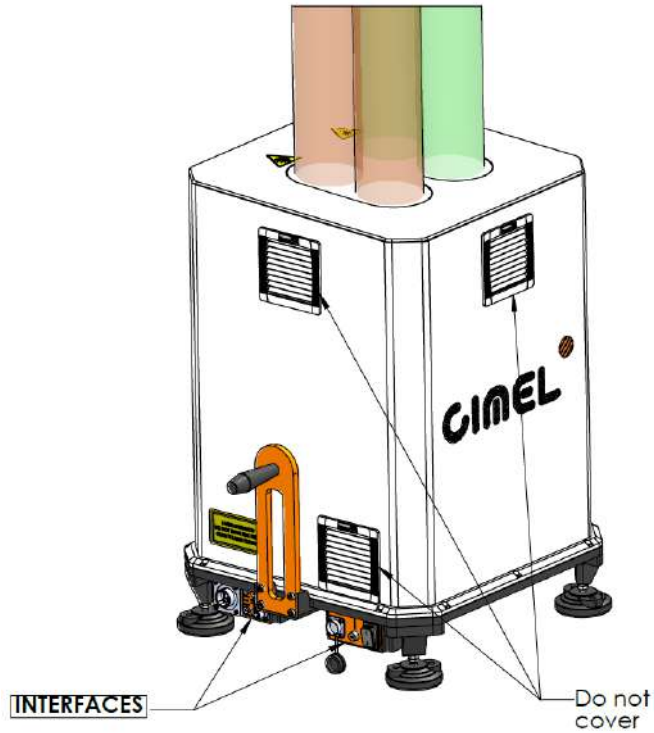

## GETTING STARTED: PREREQUISITES

1. In order to use your CE376 LiDAR you need either a thermal enclosure I376-ENC-X or a **regulated and temperate environment** with a **non-tempered glass** window on the roof or a hatch (to be used only in non-raining conditions). In either case, determine the exact location of the complete system considering factors such as equipment and human accessibility and access control.
2. If using a thermal enclosure:
  - Make sure there is sufficient space to carry the instrument around the enclosure (free area of at least 2 x 2 m<sup>2</sup> around it).
  - Make sure that the controlling PC is not too far from the enclosure (an ethernet connection is needed between the lidar and the PC: see below)
  - If temperature and humidity are high, a dehumidifier is needed inside the enclosure.
3. If using a room :
  - Provide sufficient space for the complete system (free area of at least 2 x 2 m<sup>2</sup>).
  - Provide an access control system to the room to ensure laser safety.
  - Provide air-conditioning in the room (23°C ± 5°C).
  - Provide optical access to the sky through a roof hatch or an opening window.
  - Provide a table in the room, with power outlet nearby for the PC
4. Inside the room or the thermal enclosure, place your CE376 LiDAR in as follows:
  - It is preferable to place the CE376 LiDAR in a **shady place**.
  - If the site is in the **tropical zone**, protect the LiDAR from direct sunlight at midday.
  - If the site is in the **Northern** Hemisphere: place your CE376 LiDAR with its lower side pointing **North**.
  - If the site is in the **Southern** Hemisphere: place your CE376 LiDAR with its lower side pointing **South**.
  - If the site is close to Equator (up to 30 ° latitude N or S): tilt the lidar by 5° inclination using the lidar feet

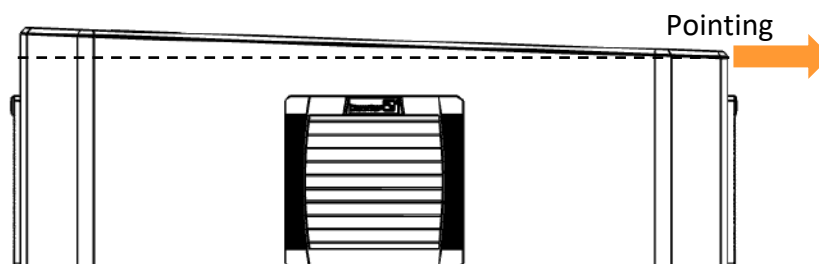

EXPLORE THE CLIMATE

5. Acquisition PC specifications needed to use CIMEL software:

| Characteristics       |                               |
|-----------------------|-------------------------------|
| Processor (CPU)       | Intel Core i7 / Intel Core i9 |
| RAM                   | 64 Go                         |
| Storage               | SSD 2 To                      |
| USB port              | 6                             |
| Ethernet port         | 2                             |
| Operating System (OS) | Windows 10 pro 64 bits        |

6. If maintenance operations are required, provide a clean, air-conditioned work area.

## LIDAR INSTALLATION

### FIRST STEPS OF THE INSTALLATION

1. Remove the blue plastic tape from all glasses or windows
2. Remove the covers over LINK connector and POWER SUPPLY connector and connect the communication cable and the power supply cable, respectively.

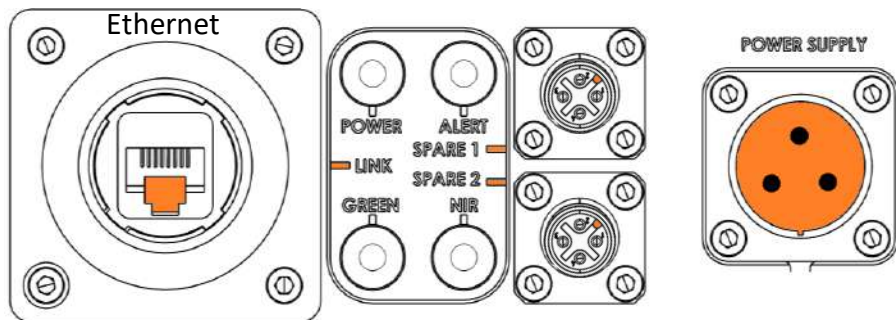

3. Connect the other side of the communication cable to the Link port of the Ethernet-USB converter box, and the USB cable connector USB B to the other port.



4. Install the software Lidar2.exe and drivers on your computer following the Software Manual instructions (provided on the USB key).
5. Connect the USB cable to your computer and Power ON your CE376 LiDAR.
6. **On the Interface** of your CE376 LiDAR, all external LEDs should blink green for 1.8s then go OFF except for the POWER LED that should stay green [A].

EXPLORE THE CLIMATE

7. After clicking on the POWER ON button from the Lidar2.exe software, both the GREEN and NIR LEDs should turn green to indicate that both lasers are switched ON. If any of the laser LEDs is blinking green, this means the laser source needs time to reach nominal temperature (few seconds to 3 minutes) before firing [B].
8. After a few seconds, the POWER, GREEN and NIR LEDs should all be green. All lasers are ON [C].
9. Monitor operations and measurement data with lidar2 software. Refer to the Lidar2 user manual.

➔ Note that if the model of your CE376 LiDAR doesn't include one specific wavelength (GP, G or N), the corresponding laser source LED will be disabled.

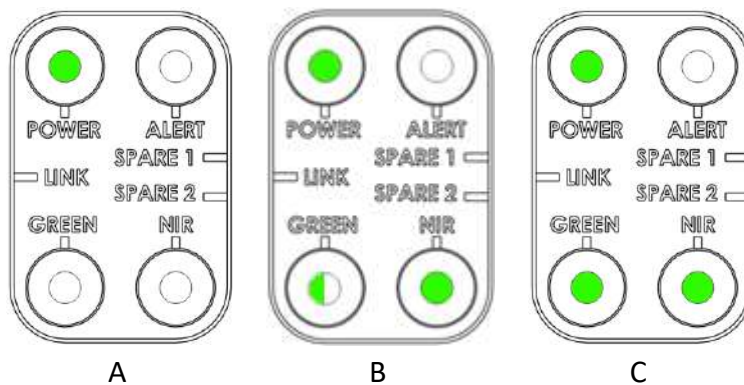

**OPERATIONAL VERIFICATION WITH CIMEL SUPPORT**

1. **Verification of no maladjustment:**
  - Take a screenshot of the LiDAR signal as soon as the LiDAR starts firing (at night) for a duration of 30 minutes with an integration time of 600 seconds under clear, rain-free weather conditions.
  - Contact CIMEL by sending this screenshot.
  - Send the lidar data files (.lid2 in C:\Lidar\LidData) to CIMEL at the email address: [support@cimel.fr](mailto:support@cimel.fr).
  - CIMEL will perform an initial diagnosis.
2. **Performance verification:**
  - Conduct LiDAR measurements day and night (over a period of one day) under the same conditions detailed above.
  - Send the LiDAR data to CIMEL at the email address: [support@cimel.fr](mailto:support@cimel.fr).
  - CIMEL will perform a performance diagnosis.



**3. Polarization calibration:**

- If the diagnosis is positive, CIMEL will propose a meeting via TeamViewer.
- Before this meeting, download TeamViewer from: <https://www.teamviewer.com>
- On the day of the meeting, exchange TeamViewer access codes to allow CIMEL access.
- CIMEL will remotely perform the polarization calibration.

**4. Overlap function correction:**

- The client sends one week of LiDAR data to CIMEL under well-mixed aerosol conditions (homogeneous PBL).
- CIMEL will remotely perform the overlap correction function based on the daily data.

**5. Issuance of commissioning report:**

- CIMEL will issue a commissioning report including quality control and calibration coefficients for polarization and the overlap correction function.

In case of a negative result in steps 1, 2, and 3, it will be necessary to send a CIMEL-certified operator on-site. CIMEL will contact the client to arrange the intervention.

EXPLORE THE CLIMATE

## THERMAL ENCLOSURE OPTIONS

| Model                            | I376-ENC-1   | I376-ENC-2        |
|----------------------------------|--|-------------------|
| <b>Power Supply</b>              | 115 VAC (50Hz/60Hz)  |                   |
| <b>Typical Power Consumption</b> | 1300 W   |                   |
| <b>Cooling Capacity</b>          | 3940/4104 BTU/Hr.  | 5585/6180 BTU/Hr. |
| <b>Operating Conditions</b>      | Temperature: -30°C – +55°C / -22°F – 130°F<br>Humidity: 0% – 100%<br>An additional internal dehumidifier is needed if temperature and humidity are high (Due point temperature > 19°C) |                   |
| <b>Dimensions</b>                | 90 x 95 x 130 cm / 35.4 x 37.4 x 51.2 in   |                   |
| <b>Weight</b>                    | 93 kg / 205 lb   |                   |

| Model                            | I376-ENC-3   | I376-ENC-4        |
|----------------------------------|--|-------------------|
| <b>Power Supply</b>              | 230 VAC (50Hz/60Hz)  |                   |
| <b>Typical Power Consumption</b> | 1300 W   |                   |
| <b>Cooling Capacity</b>          | 4269/4703 BTU/Hr.  | 5469/5965 BTU/Hr. |
| <b>Operating Conditions</b>      | Temperature: -30°C – +55°C / -22°F – 130°F<br>Humidity: 0% – 100%<br>An additional internal dehumidifier is needed if temperature and humidity are high (Due point temperature > 19°C) |                   |
| <b>Dimensions</b>                | 90 x 95 x 130 cm / 35.4 x 37.4 x 51.2 in   |                   |
| <b>Weight</b>                    | 93 kg / 205 lb   |                   |

With this option, connect your CE376 LiDAR to the cables inside the Thermal Enclosure and connect externally the Power Supply cable and the communication Cable delivered with your CE376 LiDAR to the Thermal Enclosure on the outside.

EXPLORE THE CLIMATE

**HEALTH & CARE****CLEANING THE WINDOW OF THE LIDAR**

Depending on the weather conditions, it is recommended to clean the CE376 LiDAR window with an optics cloth when needed.

If your CE376 LiDAR is in a Thermal Enclosure, clean the window of the thermal enclosure with water and a smooth optics cloth when needed.

**CLEANING VENTS**

Use a soft brush or compressed air to clean any vents or openings to prevent dust build-up.

**POWER SUPPLY AND CONNECTIONS INSPECTION**

Inspect and clean the LiDAR's power supply and connections to ensure proper functioning.

**TEMPERATURE INSIDE YOUR CE376 LIDAR**

In Lidar2.exe software, check the stability of the temperature inside your CE376 LiDAR. If any anomaly occurs, check that the thermal enclosure is working properly.

**AFTER-PULSE CALIBRATION**

It is recommended to perform an After-Pulse calibration every month. Put a dark cloth over the outside window of your CE376 LiDAR in order to block laser light completely and perform an After-Pulse Calibration with the software Lidar2.exe for 600 s.

**POLARIZATION CALIBRATION**

It is recommended to perform a polarization calibration twice a year on your CE376 LiDAR. Contact Support for remote assistance (necessitates a remote intervention on the acquisition PC).

**ROUTINE MAINTENANCE**

To ensure the highest performance, it is recommended to ask for a service check-up maintenance of your CE376 LiDAR every year by a CIMEL-qualified operator. This check-up is not included in the warranty of the product.

**MOVING YOUR CE376 LIDAR**

If you plan to use your CE376 LiDAR on a field campaign or at another site, it is essential to handle the instrument with care. Always use the designated carrying case with protective foam to ensure the safety and integrity of the device during transportation. Proper handling and secure packing will help prevent any potential damage and maintain the instrument's optimal performance.

**SOFTWARE UPDATES**

Regularly check for software updates provided by CIMEL (CimelUpdate.exe) and install them as needed to ensure optimal performance and compatibility with other systems.

## FIRMWARE UPDATES

Verify that your LiDAR uses a TEU (Telematics Electronics Unit) or PMU (Power Management Unit) card. Only versions after C of the CE376 LiDARs are equipped with these cards and can be directly updated by the user.

If your LIDAR is an older version without a TEU/PMU card, updating the firmware is not possible. Please contact CIMEL support for further assistance in such cases.

If you encounter firmware-related issues, periodically update the LiDAR firmware to the latest version provided by CIMEL.

## MAINTENANCE LOG AND INCIDENCE REPORTING

Keep detailed records of all maintenance activities, including dates, tasks performed and any replacement parts used.

Report any recurring issues or trends to CIMEL for further investigation and resolution.

## SPARE PARTS

Here is a list of spare parts for the CE376 LiDAR:

| Accessory        | Description                |
|------------------|----------------------------|
| Cable            | Data cable,<br>Power cable |
| USB extender box | To be connected on the PC  |

## TROUBLESHOOTING

| Problem  | Possible Solution   |
|--|---|
| <b>GREEN LED blinks green</b>                  | The laser is reaching its nominal temperature. Wait a few moments until it turns green.   |
| <b>GREEN LED blinks red</b>                    | Green laser issue. Power OFF your CE376 LiDAR in the Lidar2.exe software and Power ON again.<br>If the problem persists, Power OFF your CE376 LiDAR with the main switch, wait a few seconds and switch Power ON. |
| <b>NIR LED blinks green</b>                    | The laser is reaching its nominal temperature. Wait a few moments until it turns green.   |
| <b>NIR LED blinks red</b>                      | NIR laser issue. Power OFF your CE376 LiDAR with the main switch and disconnect from the power outlet. Wait a few seconds before plugging it back and Power ON.   |
| <b>ALERT LED blinks red</b>                    | Internal issue, please contact Support.   |
| <b>All LED green but no laser beam visible</b> | The NIR laser source is invisible to the eye.<br>By day the green laser beam can be difficult to see.<br>To check if the green the laser is on, put a white paper sheet above the lidar to see the laser beam.    |

|   |  |
|---|--|
| <p><b>The CE376 LiDAR doesn't power ON</b></p>                | <p>Verify that the Instrument is plugged into an electrical outlet.</p> <p>If there is no issue with the electrical outlet, check the condition of the fuse. In case the fuse is damaged, replace it by a new one with the same characteristics (slow blow T6.3A).</p> <p>If the CE376 LiDAR is used with the optional CIMEL Thermal Enclosure, check if the circuit breaker inside is properly operating.</p> |
| <p><b>Droplets or dew on the thermal enclosure window</b></p> | <p>This may happen in the morning and/or after rain. Remove the water from the glass manually, or let it evaporate by itself after a few hours.</p>  |
| <p><b>Condensation in the thermal enclosure window</b></p>    | <p>Use a dehumidifier.</p>   |

If any of these issues persist, please contact Support.

**TECHNICAL SUPPORT**

If previous steps didn't solve your issues, contact CIMEL technical support at [support@cimel.fr](mailto:support@cimel.fr).

Avoid attempting repairs on your own, that could void the warranty or cause further damage to the LiDAR unit.

The support team will try to establish a diagnosis based on LiDAR data analysis (.lid2 files) and propose corrective actions: Intervention of a CIMEL-qualified operator on-site or return LiDAR to CIMEL workshop.

**CONSUMABLES**

| Accessory   | Lifespan               |
|-------------|------------------------|
| NIR Diode   | 25 000 operating hours |
| Green laser | 50 000 operating hours |
| APD         | 10 years               |

The replacement of these parts must be carried out by a CIMEL-qualified operator.

This operation can be carried out on-site (in a clean, air-conditioned room) or in CIMEL factory.

## WARRANTY INFORMATION

### TERMS & POLICY

CIMEL warrants all its products to be of the highest quality in materials, workmanship and service for one year from the date of delivery, covering the instrument as a whole and its components.

CIMEL provides remote support to assist with any issues that may arise. This includes providing contact with our support team who can offer guidance and troubleshooting advice.

If remote support is insufficient to resolve the issue, CIMEL will arrange for an equivalent technician to provide on-site assistance. Alternatively, the instrument may need to be returned to our workshop for further inspection and repair.

The validity of this warranty is contingent upon the correct use of the instrument. CIMEL reserves the right to void the warranty after diagnosis at the CIMEL factory if it is determined that the conditions of proper use have not been met. This may include, but is not limited to, evidence of misuse, unauthorized modifications, or improper maintenance.

## CUSTOMER SUPPORT

### CIMEL

172 Rue de Charonne  
75011 PARIS  
FRANCE

Email: [support@cimel.fr](mailto:support@cimel.fr)

\*Please have the Model and Serial Number of your CE376 LiDAR ready before contacting Customer Support.

